

COUPE B-B
ECHELLE 1 : 5

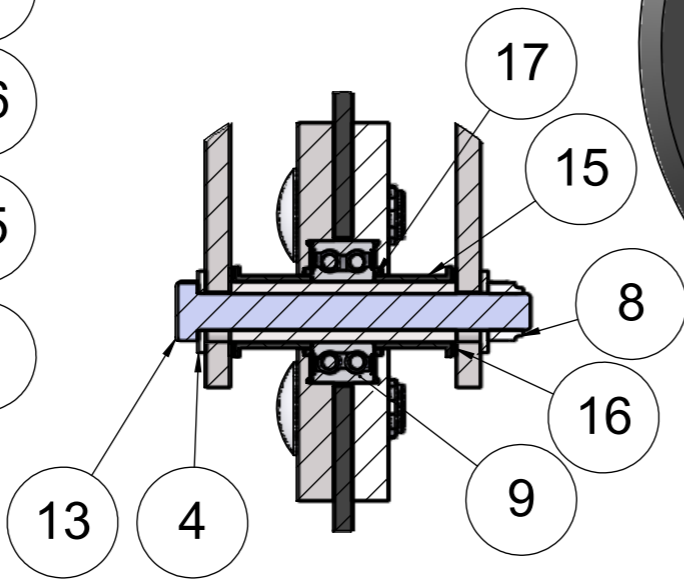

DÉTAIL C
ECHELLE 2 : 5

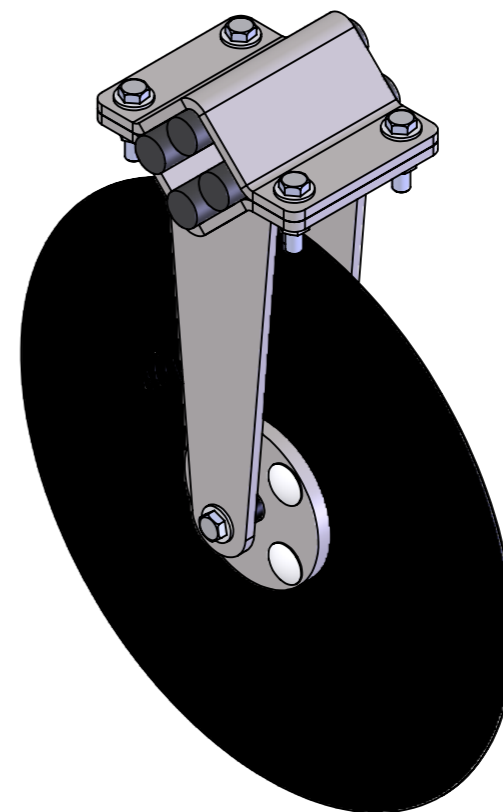
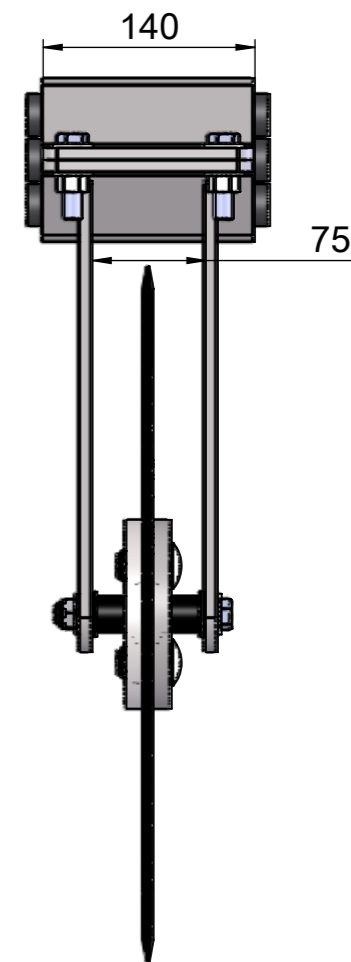
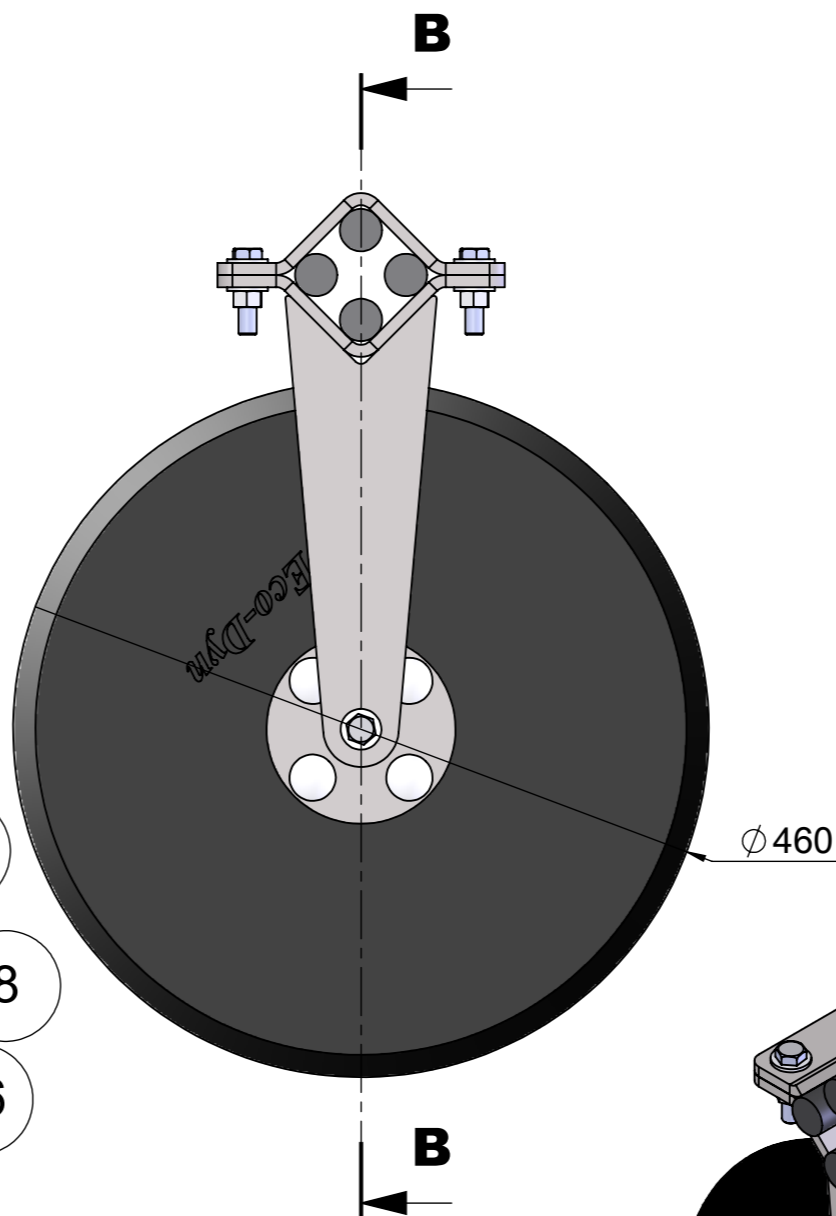

N°	Ref pièce	Ref Plan	Quantité	Description
1	100109	100007	1	Bride support disque
2	RAD.SD.100	100008	1	Support disque
3	100261	100261	4	Corde caoutchouc Ø28x160
4	100212	-	14	Rondelle plate M12, NFE 25-514
5	100204	-	4	Ecrou Hu, M12-8-ISO4032 Bichro
6	100269	100269	1	Disque lisse Ø460x5
7	100267	100068	1	Axe Ø20/12x75
8	100213	-	5	Ecrou frein M12 DIN985
9	l1-3204_a-2rs1-2_3	-	1	Roulement 3204 2RS
10	101336	101336	1	Platine support roulement/disque
11	101337	101337	1	Platine support roulement/disque
12	Vis trcc-12x35	-	4	Vis TRCC M12x35 classe 8-8
13	100271	-	1	Vis H, M12x110-8.8 ISO4014 Bichro
14	100666	-	4	Vis H, M12x50-8.8 ISO4014 Bichro
15	101461	-	2	Bague Ø24xØ20 Lg26 (SKIFFY:008200059902)
16	003 20006 00001	-	2	Rondelle Ø20.2xØ29 ep1.5
17	JT 24T2.5A5	-	2	Joint torique Ø24x2.5
18	JT 45T1.5A5	-	2	Joint torique Ø45x1.5

GENERAL TOL.: ±0.5	MASS: 17 kg	DESIGN: G Dugué VERIF: Eco-Dyn	DATE: 10/03/2012 DATE: 10/03/2012
ANGULAR TOL.: ±0.5°	MATERIAL: /	SURF.TREAT: -	ROUGH.: R _a 6.3
Coutre rouleau à disque - rolling couler 101462			
		INDEX: -	SCALE: 1:10
		SHEET: 1/1	A3

Eco-Dyn
 Vernoux
 49370 Bécon les Granits
 France
 Tel : +33 2 41 77 46 11
 www.ecodyn.fr